

Displays & demonstrations

Carving – Jan Zalud

Jan Zalud started making puppets as presents from driftwood in 1978 as a distraction from painting large abstracts. In the 80s a Crafts Council grant helped him exhibit them nationally and internationally. In the 90s he became part time resident carver for Little Angel Theatre. He has also carved puppets for Royal Shakespeare Company, Norwich Puppet Theatre, Kneehigh Theatre, Polka Theatre and Puppet Theatre Barge.
https://www.instagram.com/p/C_fuN3HuYYp/



Controls

The strings of a marionette puppet hang from a 'control', typically a wooden configuration of bars. The control sits in the hand of the puppeteer, it helps balance the puppet's weight and keep the strings hanging freely with as minimal tangle as possible. It enables the puppeteer to control multiple puppet parts at once. Controls come in different designs, some basic, some complex. Here is a display of just some of the designs used both here in the UK and internationally.

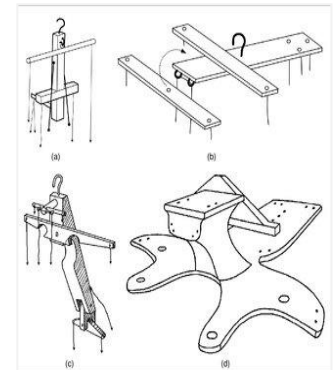

D-Forms & marionettes – Oliver Smart & Aqiong Zhang

Last month AWG hosted a workshop for a group of puppet makers, co-led by Guild members Tony Wills and Rachel Warr. They explored D-Forms, a branch of geometry discovered by Tony Wills, in which flat shapes are constructed into 3D. The challenge was to combine these as abstract puppet forms and see how they might be articulated via strings. Find out more from makers who attended the workshop.
[instagram.com/p/DAHOz7hod8b/](https://www.instagram.com/p/DAHOz7hod8b/)



Displays & demonstrations

Have a go - Roger & Julie Lade

After completing a Fine Art Degree, mostly concentrating on drawing and painting from life, Roger Lade started making puppets and masks to include in his still lifes. Intrigued by puppetry he did a marionette carving course at the Little Angel and then became a puppeteer there. He met Julie, now his wife, and together they created puppet shows including: Tales of Magic & Monsters, The Ghosts of Redbeard Castle, and Mozart with Puppets.



Have a go – Ronnie Le Drew

Ronnie Le Drew started his career at the Little Angel Theatre directed by John and Lyndie Wright. This followed jobs with the Hogarth Puppets famous for TV's first marionette icon "Muffin the Mule" Clifford Heaps miniature Theatre, and John Blundall's Company at the Midlands Art's Centre. His work for Television and Film has been extensive, as has his teaching experience. His biography "Zippy and Me" was published in 2019.



Marionettes & small films – Tony Sinnett

Tony Sinnett has been making marionettes for tv/films and music videos for the last two decades. He has progressed to producing his own short films and music videos with the last big project, for Elvis Costello, being completely produced in house. He has worked recently for Harry Enfield, reproducing a copy of Muffin the Mule and also created an execution puppet scene for 'My Lady Jane' which is currently on Amazon Prime.

www.companyofmarionettes.com/tonysinnett

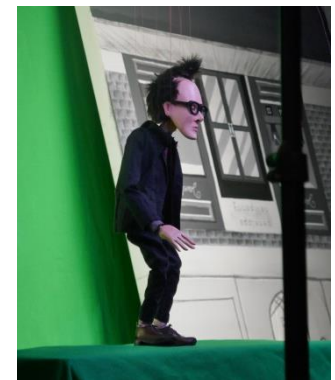

Displays & demonstrations

Marionettes Victorian to present day

Michael Dixon / The National Puppetry Archive

How have British marionettes changed from Victorian times through the 20th century? Michael Dixon has brought along some historical marionettes from The National Puppetry Archive. The archive consists of two main collections: the archive of The British Puppet and Model Theatre Guild, and Michael's personal collection as its Archivist. Michael will be on hand to demonstrate how these marionettes perform. www.nationalpuppetryarchive.co.uk



Music & Marionettes, The Pigeon & The Peacock

Quanimals Productions / Miranda Lewis-Brown & Bori Mezö

'The Pigeon & The Peacock' is a new show currently touring libraries and community venues. Written and composed by jazz cellist Miranda Lewis-Brown, and performed with singer-pianist Tereza Catarov and puppeteers Soledad Zárata and Borbála Mezö. The bird marionettes, with complex mechanisms and delicate surface decoration, were made by Sarah Vigers. Find out about the teams' creative process and how music and marionettes compliment one another.



Recreating biological mechanics – Laura Mathews

Laura Mathews is an artist and puppet maker who is deeply fascinated by biological mechanics. Her work investigates the details of animal locomotion, carefully recreating them using a blend of contemporary and traditional woodworking techniques. Each puppet can take years of meticulous anatomical research, prototyping and refining. Originally, Laura made posable animal sculptures, before returning to her childhood love of marionettes, bringing her work to life in a new way.

www.lauramathewsart.com



Displays & demonstrations

Tailoring costumes for marionettes – Keith Frederick

Keith Frederick is a puppet and costume designer and maker. Keith has been collecting, making, performing with marionettes since the age of 5. In 2010 Keith was asked to design and build puppets for the Little Angel Theatre's production of 'Dog's Don't do Ballet'. Since then, Keith has designed and built puppets and puppet costumes for Theatre, TV and Film. He has also taught puppet making at The Wimbledon School of Art.
www.puppetsurgery.com

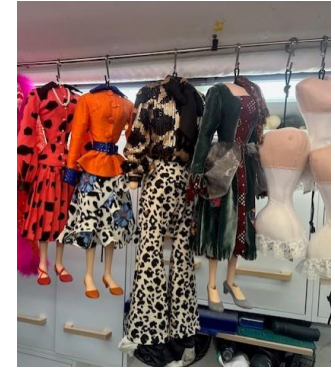

The Adventures of Finocchio- A Toy Theatre Marionette show /Have a go Charlotte Cory

Artist, author, Brother of the AWG, and creator of The Grand Visitoria toy theatre (available from Benjamin Pollocks in Covent Garden), Charlotte Cory decided to carve some puppets and put on a show. Her uncooperative puppets have other ideas. Outraged by her incompetence and the pathetic production, they rebel and demand contracts and fees. And biscuits. They disrupt every performance and encourage the audience to do so too. It's puppetry (of sorts) but not as you know it. www.charlottecory.com



Trick marionettes from The Insect Circus – Soledad Zárate / String Theatre

String Theatre is a London-based touring company that presents long string marionette productions, with recent awards from festivals in Spain and Italy. The marionettes from *The Insect Circus* are 'Trick marionettes', designed to perform 'trick' moves via unique combinations of strings and mechanisms. Designed and made by Stan Middleton, Soledad Zárate and Sarah Fitzpatrick.
www.stringtheatre.co.uk



Short performances

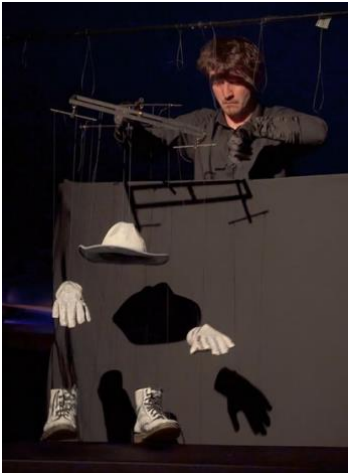

Liminal

In a series of wordless movements that explore space and object relationships, the show invites a liminal space where boundaries of the human form are manipulated and reimagined through marionettes and music.

Tatwood Puppets

Since forming in 2017, Newcastle upon Tyne-based company Tatwood Puppets have produced a diverse body of work across a range of mediums, specialising in marionettes, original music, table-top puppetry and parlour magic.

www.tatwoodpuppets.co.uk



Entwine

Marionettist Alicia Britt and dancer Anna Smith are collaborating on a new performance. How do human bodies and marionette bodies differ? What are their unique qualities or limitations? In this short (in development) performance, dancer, puppet and puppeteer spin, glide and tangle in a joyful exploration of bodies in motion and connection.

Alicia Britt is a puppet maker and performer, she is currently a QEST scholar exploring marionette carving. Anna Smith is a dance artist who trained at Rambert Dance. Alicia and Anna met while working at ROH.

And more, including:

The Insect Circus

An historical cabaret Harlequin

See programme of events on arrival